

**MGK LTD SURVEY
LOT 15, THOMPSON TOWNSHIP
GEAUGA COUNTY, OHIO**

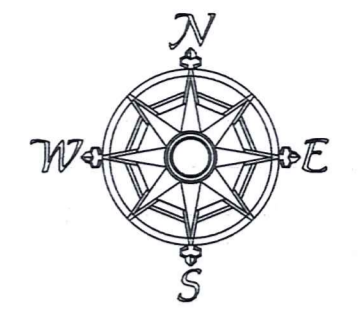

All bearings are to an assumed meridian and indicate angles only.

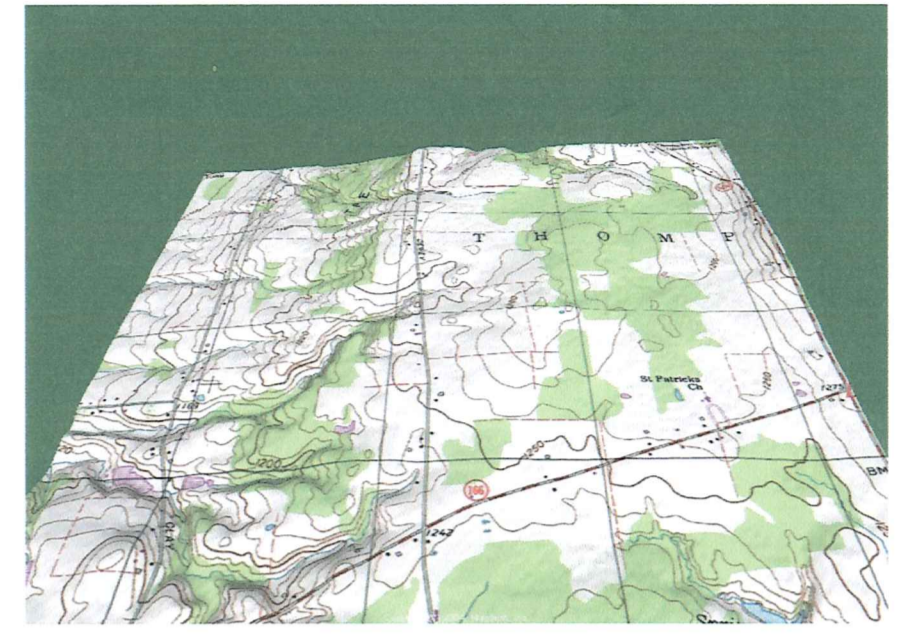
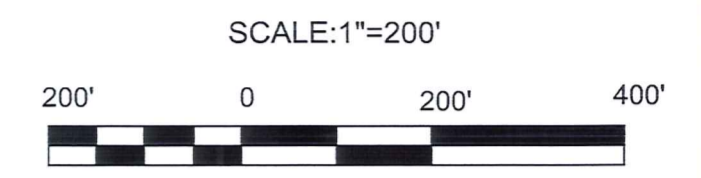

04-14-05
06-14-05

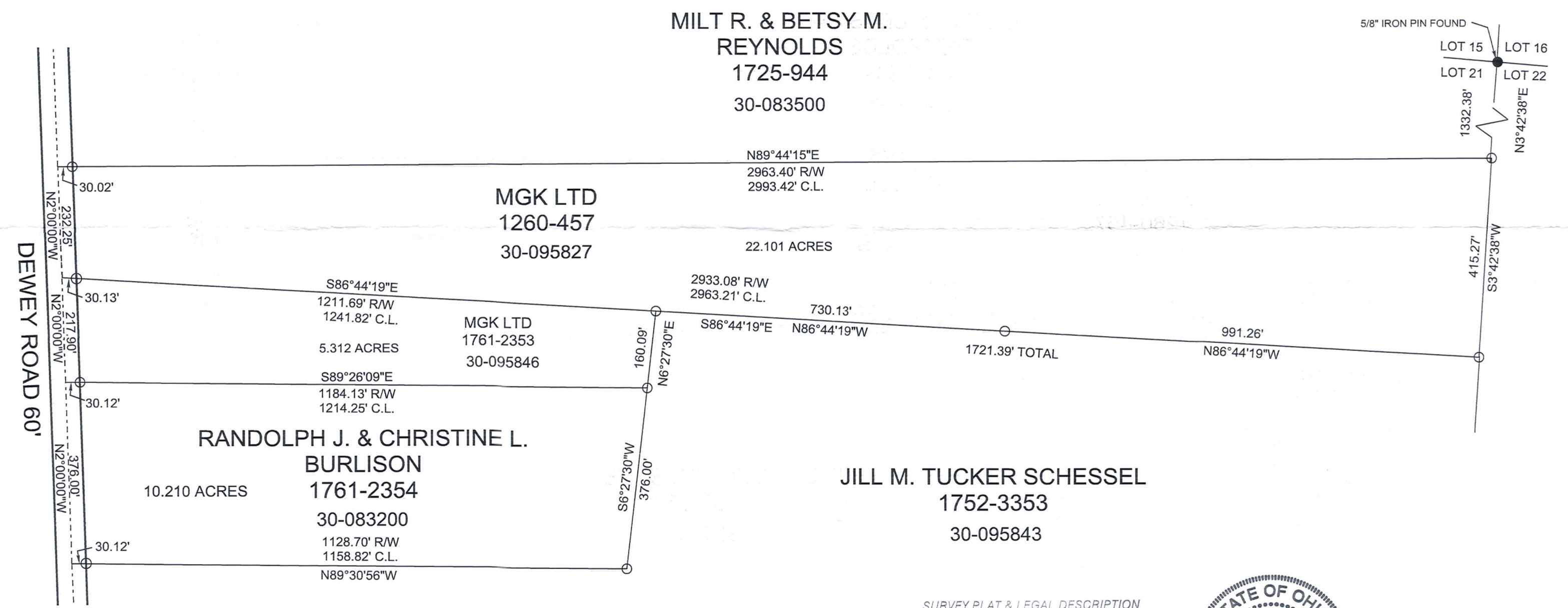

SURVEY PLAT & LEGAL DESCRIPTION
APPROVED PER R.C. 315.251
PAY 6/16/05
OFFICE OF THE
GEAUGA COUNTY ENGINEER



I hereby certify that I have surveyed this parcel and that the same is true and correct. This parcel was surveyed in accordance with the provisions of Chapter 4733-37 of the Ohio Administrative Code.

Jerry Slay 6-16-05
Jerry Slay, P.E. P.S.
Ohio Surveyor Number 5298

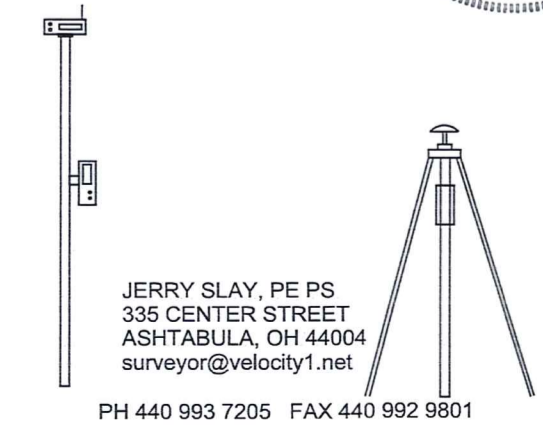

LEGEND

○	5/8" CAPPED "SLAY 5298" IRON PIN FOUND
●	5/8" IRON PIN FOUND

PERTINENT DOCUMENTS: SLAY SURVEY; 01-05

FILE NAME		
MGK LTD 10 ACRE SPLIT DEWEY ROAD.TRV		
SCALE	DATE	DRAWN BY
200 Ft/in	6-16-2005	JDS
JOB	REVISION	SHEET
	1/1	1/1

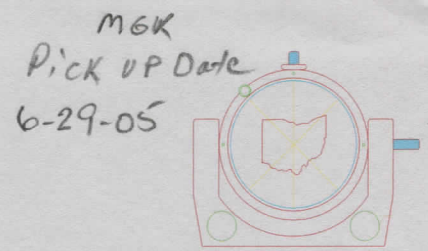
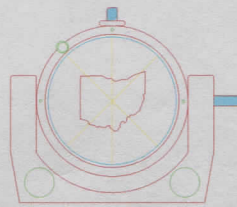
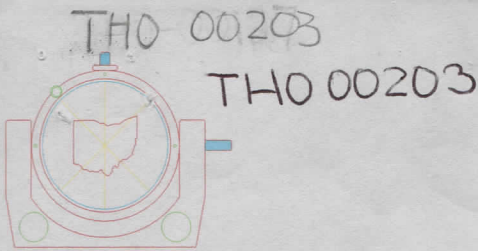

335 CENTER STREET
ASHTABULA, OHIO 44004

JERRY SLAY, P.E., P.S.
REGISTERED LAND SURVEYOR
PROFESSIONAL ENGINEER

PHONE (440) 993-7205
FAX (440) 992-9801
E-MAIL: surveyor@velocity1.net

JUNE 14, 2005

DESCRIPTION OF LANDS OF MGK LTD, AS RECORDED IN DEED VOLUME
1260-457:

SITUATED IN LOT 15, THOMPSON TOWNSHIP, GEAUGA COUNTY, OHIO:

BEGINNING AT A 5/8" IRON PIN FOUND AT THE INTERSECTION OF LOTS 15,
16, 21 & 22 AND THENCE SOUTH 03 DEGREES 42 MINUTES 38 SECONDS WEST
ALONG THE WEST LINE OF LOT 22, 1332.38 FEET TO A 5/8" CAPPED "SLAY
5298" IRON PIN FOUND AT THE SOUTHEAST CORNER OF MILT R. & BETSY M.
REYNOLDS (1725-944) AND THE PLACE OF BEGINNING:

COURSE 1: THENCE SOUTH 03 DEGREES 42 MINUTES 38 SECONDS WEST
ALONG THE WEST LINE OF LOT 22, 415.27 FEET TO A 5/8" CAPPED "SLAY
5298" IRON PIN FOUND AT THE NORTHEAST CORNER OF JILL M. TUCKER
SCHELSEL (1752-3353);

COURSE 2: THENCE NORTH 86 DEGREES 44 MINUTES 19 SECONDS WEST
ALONG THE NORTH LINE OF SCHELSEL AND THE NORTH LINE OF MGK LTD
(1761-2353) (Passing through a 5/8" capped "Slay 5298" iron pin found at 991.26 feet, a
5/8" capped "Slay 5298" iron pin found at a corner in lands of Schessel at 1721.39 feet
and passing through a 5/8" capped "Slay 5298" iron pin found in the east line of Dewey
Road, 30.13 feet from centerline) A TOTAL DISTANCE OF 2963.21 FEET TO THE
CENTERLINE OF DEWEY ROAD:

COURSE 3: THENCE NORTH 02 DEGREES 00 MINUTES 00 SECONDS WEST
ALONG THE CENTERLINE, 232.25 FEET TO THE SOUTHWEST CORNER OF
REYNOLDS;

COURSE 4: THENCE NORTH 89 DEGREES 44 MINUTES 15 SECONDS EAST
ALONG THE SOUTH LINE OF REYNOLDS (Passing through a 5/8" capped "Slay
5298" iron pin found in the east line of Dewey Road, 30.02 feet from centerline) A
TOTAL DISTANCE OF 2993.42 FEET TO THE PLACE OF BEGINNING AND
CONTAINING 22.101 ACRES.

THO 00203

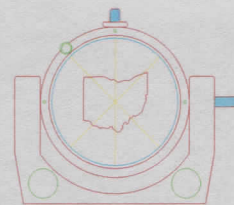
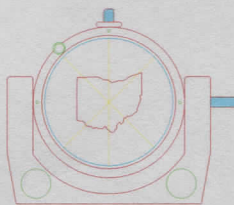
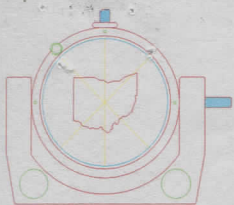

335 CENTER STREET
ASHTABULA, OHIO 44004

JERRY SLAY, P.E., P.S.
REGISTERED LAND SURVEYOR
PROFESSIONAL ENGINEER

PHONE (440) 993-7205
FAX (440) 992-9801
E-MAIL: surveyor@velocity1.net

BEARINGS ARE TO AN ASSUMED MERIDIAN AND INDICATE ANGLES ONLY.
AS PER SURVEY BY JERRY SLAY, OHIO SURVEYOR NUMBER 5298 DATED
JUNE 14, 2005.

INTENT IS TO SURVEY AND DESCRIBE 30-095827.

ALL CAPPED IRON PINS SET MARKED "SLAY 5298" ARE 5/8" X 30".



Jerry Slay
6-16-05

SURVEY PLAT & LEGAL DESCRIPTION
APPROVED PER R.C. 315.251

PAK *6/16/05*

OFFICE OF THE *Rev*
GEAUGA COUNTY ENGINEER

JUN 17 2005